

THIS DRAWING IS UNPUBLISHED. RELEASED FOR PUBLICATION
 © COPYRIGHT - By - ALL RIGHTS RESERVED.

| LOC | DIST | REVISIONS | | | |
|-----|------|-------------|-----------------------|---------|-------|
| P | LTR | DESCRIPTION | DATE | DWN | APVD |
| AF | 50 | U2 | REV PER ECO 13-010686 | 27JUN13 | JR PD |

- CONTINUOUS STRIP ON REELS
- MATING TAB THK IS $.020 \pm .001$
- WIRE SIZE IS #20-#16 AWG
- INSULATION RANGE IS $.090 - .130$ DIA

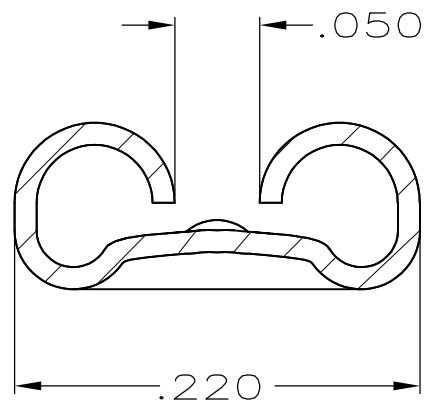
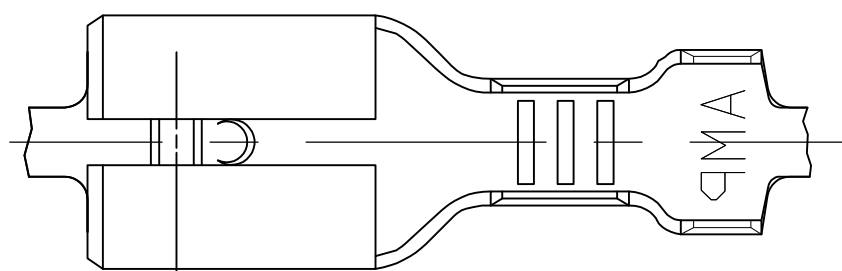

SECTION A-A
SCALE 8:1

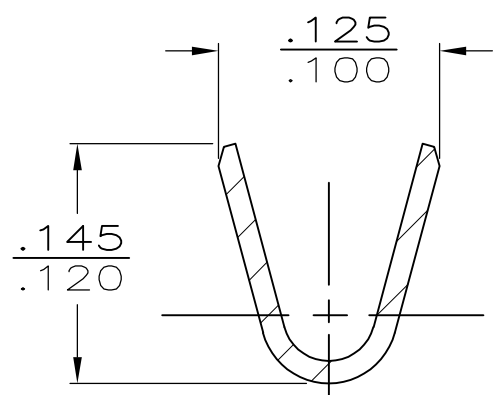
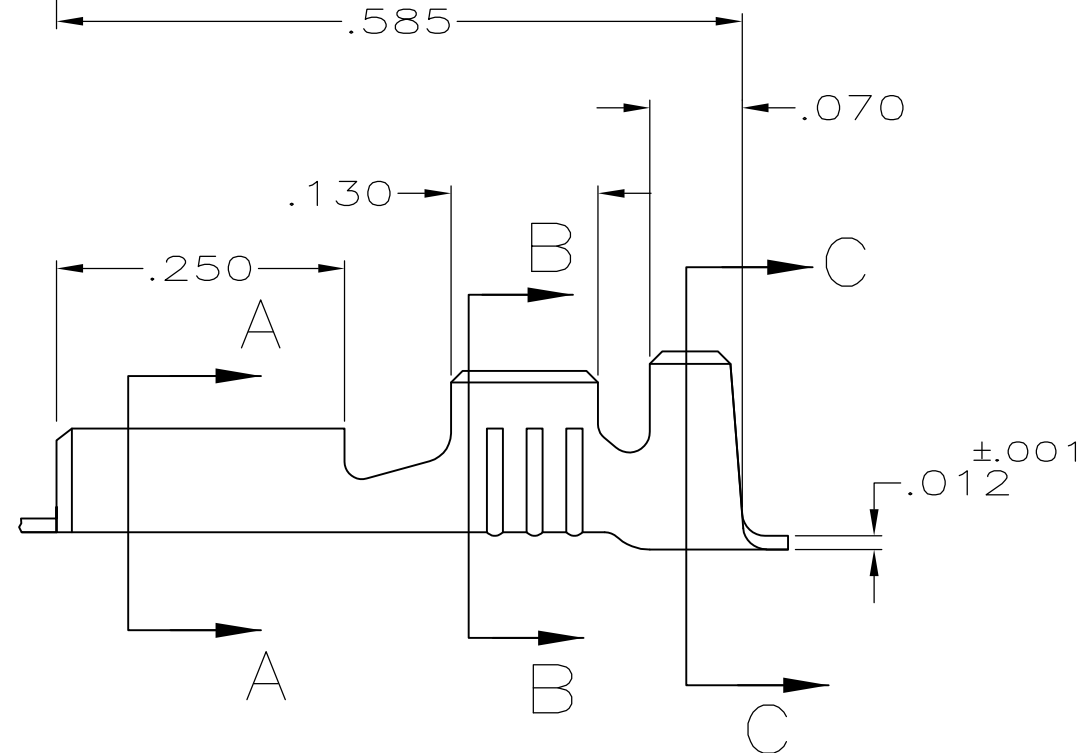

SECTION B-B
SCALE 8:1

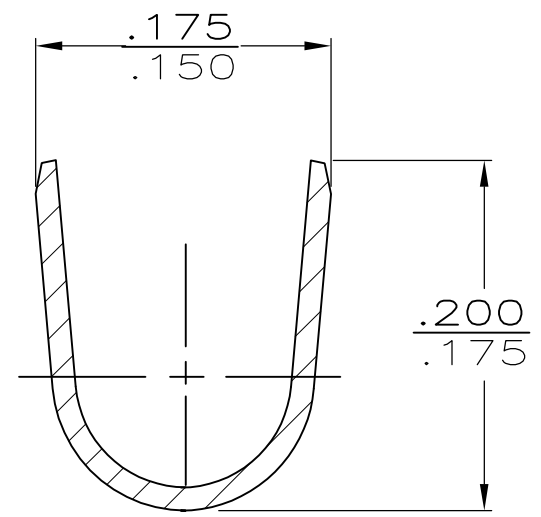

SECTION C-C
SCALE 8:1

| FINISH | MATERIAL | PART NO. |
|-------------------------|------------|--------------------|
| OBSOLETE TIN | #4H PH BRZ | 42617-4 |
| OBSOLETE - | | 42617-3 |
| TIN | BRASS | 42617-2 |
| - | | 42617-1 |

| | | | | | | | | | | | | | | | | |
|---------------------------------------------------------------------------------------------------------------------------------------------------------------------------------------------------------------------------------------------------------|-----------|------------------|-----------|----------|----------------------------|-----|-------|-----|-------|--------|-------|-----|--------|-----|------|--|
| THIS DRAWING IS A CONTROLLED DOCUMENT. | | DWN | JR RUTH | 10/27/89 | STE TE Connectivity | | | | | | | | | | | |
| DIMENSIONS: INCHES | | CHK | MS FEHER | 10/27/89 | | | | | | | | | | | | |
| TOLERANCES UNLESS OTHERWISE SPECIFIED: | | APVD | C MEYERS | 10/27/89 | | | | | | | | | | | | |
| <table border="1"> <tr><td>0 PLC</td><td>± -</td></tr> <tr><td>1 PLC</td><td>± -</td></tr> <tr><td>2 PLC</td><td>± -</td></tr> <tr><td>3 PLC</td><td>± .015</td></tr> <tr><td>4 PLC</td><td>± -</td></tr> <tr><td>ANGLES</td><td>± -</td></tr> </table> | | 0 PLC | ± - | 1 PLC | | ± - | 2 PLC | ± - | 3 PLC | ± .015 | 4 PLC | ± - | ANGLES | ± - | NAME | |
| 0 PLC | ± - | | | | | | | | | | | | | | | |
| 1 PLC | ± - | | | | | | | | | | | | | | | |
| 2 PLC | ± - | | | | | | | | | | | | | | | |
| 3 PLC | ± .015 | | | | | | | | | | | | | | | |
| 4 PLC | ± - | | | | | | | | | | | | | | | |
| ANGLES | ± - | | | | | | | | | | | | | | | |
| MATERIAL | SEE TABLE | FINISH | SEE TABLE | WEIGHT | - | | | | | | | | | | | |
| | | APPLICATION SPEC | | SIZE | A3 | | | | | | | | | | | |
| MATERIAL | | FINISH | | WGT | - | | | | | | | | | | | |
| SEE TABLE | | SEE TABLE | | WGT | - | | | | | | | | | | | |
| CUSTOMER DRAWING | | | | SCALE | 6:1 | | | | | | | | | | | |
| SHEET | | | | 1 OF 1 | REV | | | | | | | | | | | |
| U2 | | | | | | | | | | | | | | | | |